

IM-2-A5-PC0

Electrical specifications

Winding code : PC0	Symbol	Unit	Field weakening & Water cooling
Continuous torque	T_c	Nm	540
Continuous current	I_c	A_{rms}	35
Stall torque	T_s	Nm	453
Stall current	I_s	A_{rms}	28
Peak torque(for 1sec.)	T_p	Nm	810
Peak current(for 1sec.)	I_p	A_{rms}	78
Torque constant	K_t	Nm/A_{rms}	17.32
Electrical time constant	T_e	ms	6.8
Resistance (line to line at 25°C)	R_{25}	Ω	1.2
Inductance (line to line)	L_d / L_q	mH	8.2 / 10.58
Number of poles	2p		66
Back emf constant (line to line)	K_v	$V_{rms}/rad/s$	10
Motor constant (at 25°C)	K_m	Nm/\sqrt{W}	12.86
Thermal resistance	R_{th}	K/W	0.048
Thermal sensor			PTC SNM100+SNM130+Pt1000
Max. DC BUS		V_{DC}	750
Inertia of rotor	J	kgm^2	0.27
Thermal time constant	T_{th}	s	120
Max. continuous power dissipation	P_c	W	3105
Max. peak power dissipation	P_p	W	15422
Max. speed(at 600VDC)		rpm	1600
Based speed(at 600VDC)		rpm	284
Rated speed(at 600VDC)		rpm	1600

T-N curve

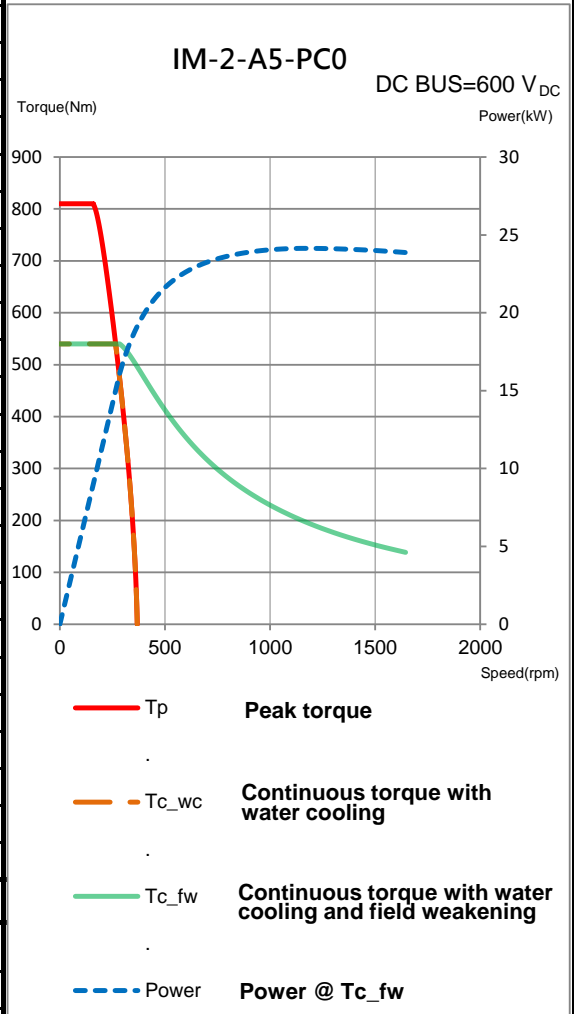

Mechanical specifications

	Symbol	Unit	Field weakening & Water cooling
Mass of rotor	M_r	kg	16.3
Mass of stator	M_s	kg	26.8
Height of stator	H_s	mm	110
Height of rotor	H_r	mm	71
Length of rotor centring fit	H	mm	20
Water temperature difference for Pc	$\Delta\theta$	K	5
Minimum water flow	q	l/min	8.9
Max. pressure drop	Δp	bar	1

Thermal sensor

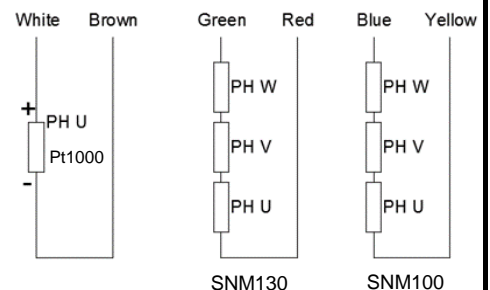
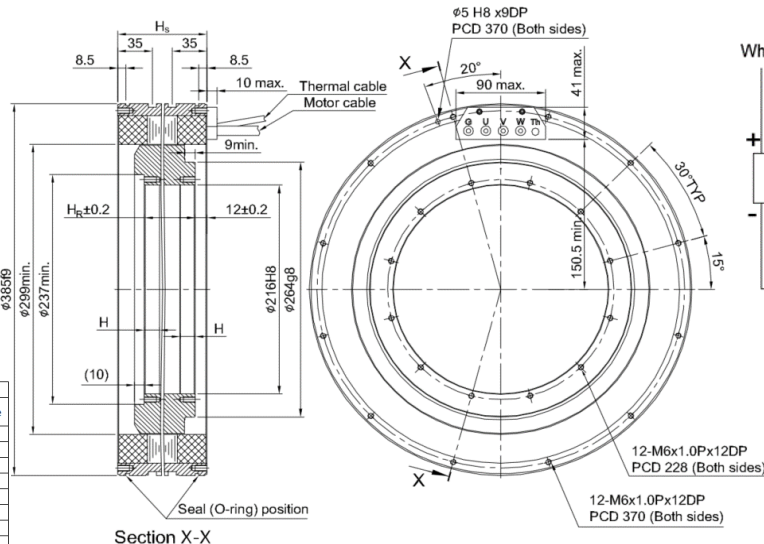

Motor wire table	
Color or wire no.	Signal
U/L1	PH U
V/L2	PH V
W/L3	PH W
Green/Yellow	GND

Except dimensions, all the specifications in the table are in ±10% of tolerance

Version: 2.00

This drawing is only for reference, detail dimensions please refer to approval drawing.

Date: 2020/11/4